



**Evergreen® EM  
Replacement Control Module Kit  
Installation Guide**

**Regal Beloit America, Inc.**  
1325 Heil Quaker Blvd.  
LaVergne, TN 37086  
Customer Service: 800-672-6495  
thedealertools.com

**FORM  
G0046E  
Revised  
June 2019**

**⚠ WARNING**

WARNING indicates a hazardous situation that, if not avoided, could result in death or serious injury.

- Read and follow all instructions carefully.
- Disconnect and lock out the main power from the unit being serviced before installing the Evergreen® EM Control Module Kit. It is also a good practice to confirm that the power is disconnected with a voltmeter.
- Do not operate equipment without guards in place.
- Improper installation, adjustment, alteration, service, maintenance, or use could cause explosion, fire, electrical shock, or other conditions. Consult a qualified installer, service agency, or your distributor or branch for information or assistance. The qualified installer or agency must use the supplied or recommended parts when installing or servicing this product.

**⚠ CAUTION**

CAUTION indicates a hazardous situation that, if not avoided, could result in minor or moderate injury.

- Periodic inspections should be performed. Failure to perform proper maintenance could result in premature product failure.
- Installation and service of this Evergreen EM Control Module Kit should be performed only by trained service technicians familiar with this kit.
- This EM Control Module Kit should be installed in accordance with accepted practices and installation instructions, and in compliance with all national and local codes.

**This Installation Guide covers all of the models listed below.**

**Application Notes:**

1. The Evergreen EM Control Module can be used to replace ECM Control Modules in the following motors ONLY: Genteq® Models X13®, Endura® Pro and Evergreen EM. All of these motors are built with control connections identical to the image to the right.
2. For proper replacement, match the horsepower (HP) and voltage (VAC) ratings of the new control to the control being replaced. It is not necessary for the RPM or the Amperage (FLA) to match.
3. This kit includes:
  - 1 - Evergreen EM Control Module
  - 2 - Control mounting bolts
  - 1 - Low Voltage Harness (OPTIONAL)
  - 1 - Motor ID label

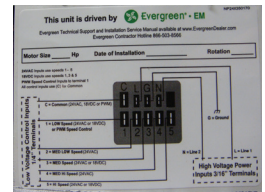
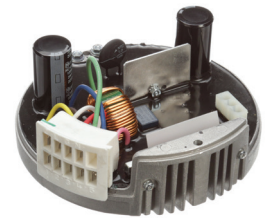
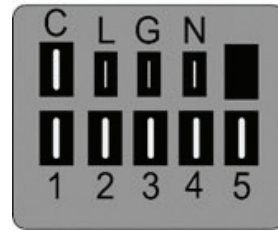

**Specifications:**

Allowable Voltage Range: 115 VAC models (90-132 VAC)  
208-230 VAC models (180-264 VAC)

RPM: 1075

Speeds: 5 (24 VAC inputs)  
3 (24 VDC inputs)  
PWM (600-1200 RPM range)

Rotation: Dual - Auto Rotation Sensing

Ambient Rating: 1/3 & 1/2 HP models (-20 to 65°C)  
3/4 & 1 HP models (-20 to 45°C)

Encapsulated Electronics

Electronic Overload Protection

4kv Surge Protection

UL and CSA Recognized Component

Stock #	HP	VAC	MAX CURRENT	ROTATION
<b>6103ECTL</b>	1/3	115	4.8 A	CCW/CW
<b>6105ECTL</b>	1/2	115	6.8 A	CCW/CW
<b>6107ECTL</b>	3/4	115	8.4 A	CCW/CW
<b>6110ECTL</b>	1	115	10.9 A	CCW/CW
<b>6203ECTL</b>	1/3	208-230	2.8 A	CCW/CW
<b>6205ECTL</b>	1/2	208-230	4.1 A	CCW/CW
<b>6207ECTL</b>	3/4	208-230	6.0 A	CCW/CW
<b>6210ECTL</b>	1	208-230	7.6 A	CCW/CW



## Installation

### CONTROL MODULE REMOVAL

1. Disconnect AC power from the HVAC system.
2. Remove wires or plugs connected to the motor control pins (CLGN and 12345).

**WARNING!** WAIT 5 MINUTES BEFORE CONTINUING.

3. Remove the (2) hex-head screws from the back of the motor control.
4. Gently remove control module from motor to expose the motor harness.
5. Unplug the 3-pin connector from the inside of the control (Depress latch).

**CAUTION!** Do not install this replacement Control Module until the Motor Module is proven to be in good working order.

**SEE MOTOR MODULE DIAGNOSTICS IN THE EVERGREEN EM CONTROL MODULE INSTALLATION GUIDE.**

### CONTROL MODULE INSTALLATION

**CAUTION!** Confirm the voltage (VAC) and horsepower (HP) rating of the new control match the control being replaced.

1. Confirm the main power disconnect is open.
2. Connect the 3-pin plug from the motor to the new control.
3. Insert the control module into the motor shell.
4. Use the supplied new bolts to secure the control module to the motor.
5. Reconnect the wires/plugs from the HVAC system to the control module inputs. See below for wiring support.

#### NOTES:

1. The first time the motor is operated, it should be mounted in the blower section to allow the rotation sensing sequence to work properly. See page 3 of this guide for more information related to "ROTATION SENSING".
2. There is a low voltage harness supplied with this kit. It is optional.
3. The terminal size and location in the new Evergreen® EM Control Module are identical to the Genteq® X13® Control Module and Endura® Pro Control Module. The original wires and/or plugs will connect to this control in the same location they were in on the failed control.
4. The speed tap VALUES (low-Hi speed) of this control module may not exactly match the speed taps of the original control. It is highly recommended to operate the HVAC system in all modes of operation, measure airflow and adjust speeds to match the system performance guidelines in the OEM manual.

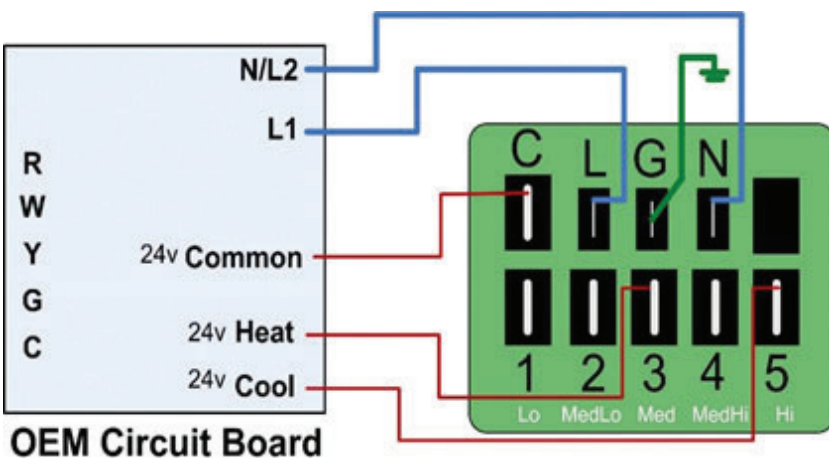
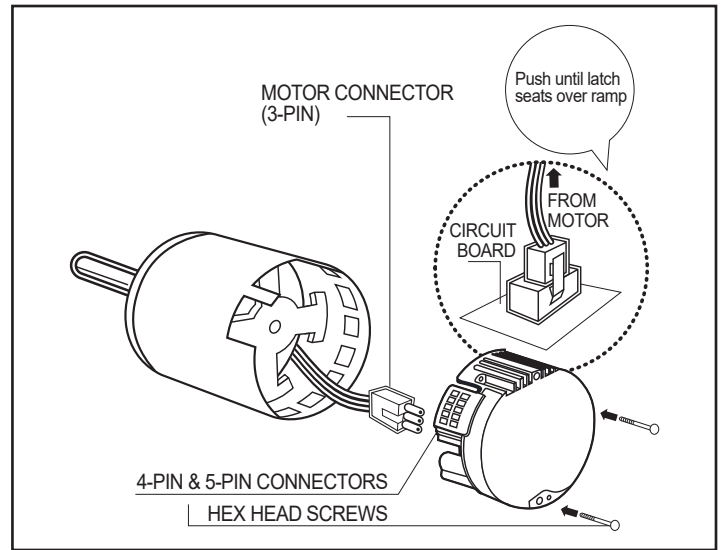

#### Electrical Inputs

- C = 24VAC Common
- L = Line 1
- G = Ground
- N = Neutral or Line 2

#### 24VAC Speed Taps

- 1 = Lo
- 2 = Med Low
- 3 = Med
- 4 = Med Hi
- 5 = Hi

## Motor Module Diagnostics

**WINDING TEST** - Set ohm meter to the highest possible setting and measure resistance between each of the three motor leads to the unpainted part of the X-brace. The motor passes the test if the meter indicates greater than 100k ohms (typical reading is infinity).

**PHASE-TO-PHASE TEST** - Set ohm meter to lowest possible setting and measure the motor phase to phase resistance by checking these combinations of the 3-pin motor connector with an ohm meter:

(lead 1 to lead 2) (lead 1 to lead 3) (lead 2 to lead 3)

For the purpose of this test, either end of the 3-pin plug is lead 1. Resistance values should be less than 20 ohms and each of the three values should be the same ( $\pm 10\%$ ). If the measure resistance is outside of these parameters, the motor fails the test.

**If the motor passes both of these tests** and the shaft spins freely when rotated by hand, proceed to installing the new control module (see page 2).

**If the motor fails either of these tests** or does not spin freely when rotated by hand, **do not install the new Evergreen® EM Control Module**, replace the failed motor and control module with an Evergreen EM motor. The Evergreen EM motor is shipped complete with a motor and a control module.

## Rotation Sensing

The first time the Evergreen® EM Control Module is powered up and receives a signal on one of the 24 VAC speed taps, it will perform a Rotation Sensing process. With this feature, the motor will automatically determine the proper operating direction of the blower wheel by running the motor for several seconds in each direction.

**Do not turn off the power to the HVAC unit until the motor continues to run in one direction.** During Rotation Sensing, the motor will run in both directions, up to four times if necessary, to determine the proper operating direction. If the proper direction cannot be determined after the fourth sequence, the motor will operate in the default direction of Counter Clock-Wise (CCW) lead end.

When the motor continues to run in one direction and increases in speed, Rotation Sensing is complete and the feature is locked out. The motor will continue to start and run in this direction without performing Rotation Sensing even if the line voltage power is disconnected.

## Troubleshooting

### If the motor does not operate:

The Evergreen EM Control Module will only operate the motor if it is receiving line voltage AND a 24 VAC speed tap input.

1. Measure the voltage between terminals (L) & (N). If proper voltage is present (voltage matching the rating on the motor control) go to the next step. If proper voltage is not present solve the issue with the HVAC system controls.
2. Measure the voltage between terminal (C) and any of the connected 24 VAC speed taps.
  - a. If 24 VAC is present at any of the speed taps, and the motor does not operate, the motor control is failed.
  - b. If 24 VAC is not present at any of the speed taps, solve the issue with the HVAC system controls.

### If the airflow needs to be adjusted:

1. Simply change the speed tap selection up or down for more or less airflow.
  - a. If the highest speed is selected and there are still airflow issues, measure the Total External Static Pressure (TESP). If it is higher than the HVAC unit manufacturer's guidelines correct the air side issue.

**If the motor is operating in the wrong direction, see page 4 for instructions on changing the rotation.**

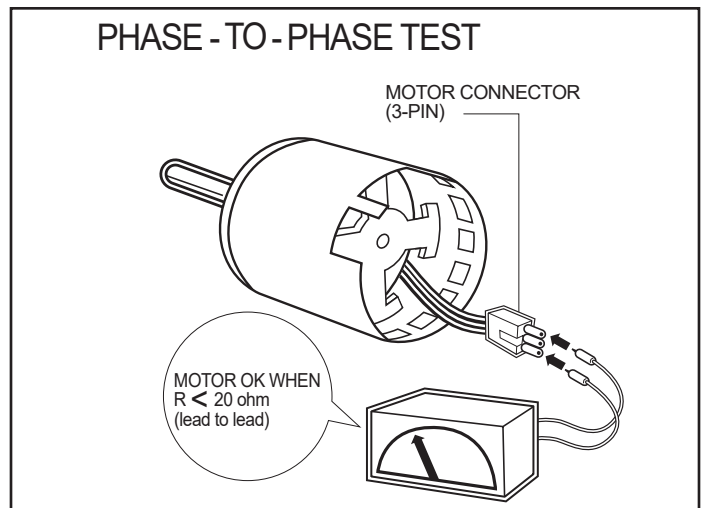
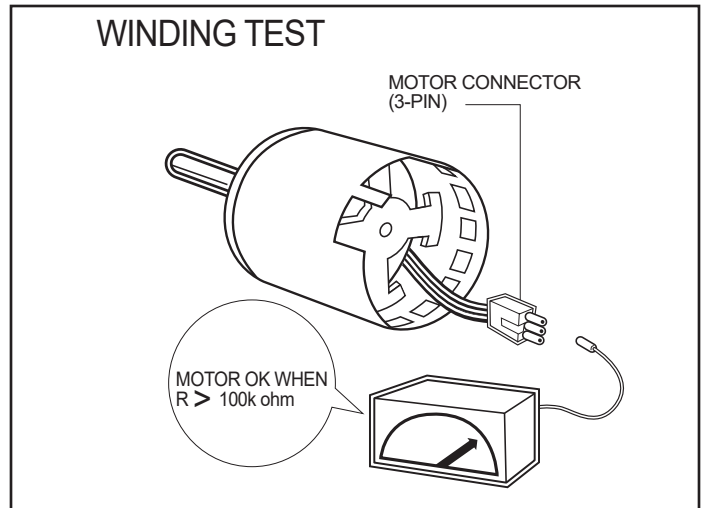

## Changing the Rotation of the Evergreen® EM Control Module

If the motor has been running for more than 1 minute, continuously in the same direction, while mounted in the blower section, the following instructions will reverse the motor.

1. Turn off the main power disconnect to the HVAC unit
2. Leave terminals C, L, G & N connected to the HVAC system
3. Disconnect all of the 24vac speed tap connections in terminals 1-5
4. Build a harness to connect only terminals 1, 3 & 5 to the thermostat (R) connection or similar 24vac power supply. (See drawing to the right)
5. Turn on the main power disconnect to the HVAC unit
  - a. Set a stop watch for 5 minutesNote: During the five minutes the motor may briefly try to start but should not run.
6. When more than 5 minutes has passed turn off the main power disconnect to the HVAC unit
  - a. Set a stop watch for 3 minutes
  - b. Reconfigure the 24vac speed tap connections to the control relays or circuit board for normal operation
7. When more than 3 minutes has passed turn on the main power disconnect to the HVAC unit
8. Set the thermostat to any demand
9. The next time the motor is energized, it will operate in the opposite direction

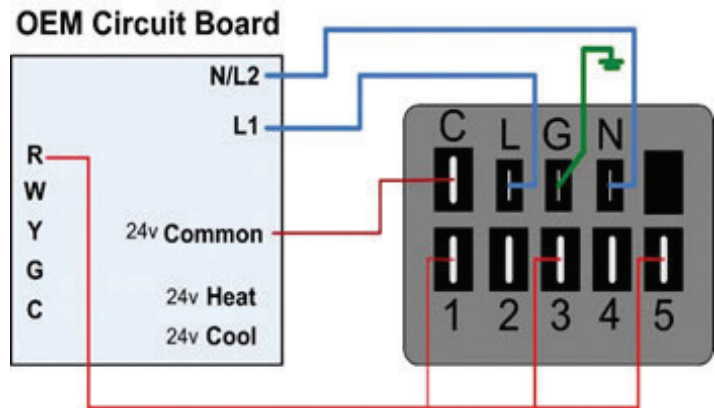

For more information and support on this product scan this QR code or go to [www.EvergreenEM-motors.com](http://www.EvergreenEM-motors.com)



For support on all Genteq® ECM products including diagnostics and training videos scan this code or search "The Dealer Toolbelt" in apple or google play.



## Terms & Conditions of Sale & Limited Warranty

Sales of the products described in this Installation Manual are subject to the "Regal Beloit Terms and Conditions of Sale" current at the time of sale. They are accessible on [RegalBeloit.com](http://RegalBeloit.com) – <https://www.regalbeloit.com> (click "Regal Terms and Conditions of Sale").

The full Limited Warranty, including the scope and period, remedies, exclusions and disclaimers, is described in Section 10 "Limited Warranty" of the Regal Terms and Conditions of Sale and applies except as described below:

Section 10(a)(1) is replaced with the following: Seller warrants that the Products shall be delivered free from defects in material, workmanship and title. This warranty shall expire twenty-four (24) months from first use of the Product or thirty (30) months from date of shipment of the Product, whichever occurs first.